



mipalloy®

Complete Competence in Copper



Projection Nut Welding Electrodes

Mipalloy is India's Largest
Manufacturer of
Projection Nut Welding Electrodes

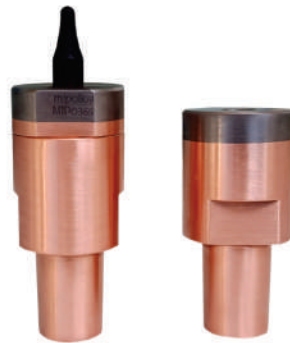

The Prematerial for our Projection Nut Welding Electrodes are from Mitsubishi Materials, Japan

Material	Chemistry	Hardness	Electrical Conductivity
Mipalloy OF, Oxygen Free Copper (UNS C10100)	Electronic grade, Cu 99.99% Oxygen Less than 5ppm	20 to 59 HRB	101% IACS
Mipalloy M75WC, Tungsten Copper	Tungsten 75% Copper 25%	93 HRB	38% IACS
Mipalloy 3ZR, Chromium Zirconium Copper (UNS C18150)	Cr 0.50-1.5%, Zr 0.05-0.25% Rest-Cu	70 to 83 HRB	75% IACS



Mipalloy Projection Nut Welding Electrodes are used in the following industries

- Automobile & Auto ancillary manufacturers
- Sheet Metal Fabricaton

Address : Plot No's. C14 & C15, SIPCOT Industrial Park, Irrungattukattai - 602 117,
Sriperumbudur Taluk, Kancheepuram District, Tamilnadu, India.

Ph: ++91-44-27156104 / 124 / 139. Mobile No: +91-9840426496 E-mail: sales@mipalloy.com web: www.mipalloy.com

Advantage of Mipalloy Tungsten Copper back cast nut welding electrode over standard nut welding electrode

Item description	Standard nut welding electrode	Mipalloy Tungsten copper back cast nut welding electrode	Performance Advantage
Bottom Electrode Nut			-
Life of electrodes in number of shifts	3 shifts	9 shifts	i) 200% increase in life ii) 63% Reduces in down time
Number of electrodes consumed per month	10 no's	3 no's	70% reduction in electrodes used
Cost of electrodes consumed per month	INR 3000	INR 1800	66% reduction in consumable cost
Quality	<ul style="list-style-type: none"> ✓ Weld separation ✓ ovality formation leading to hole misalignment ✓ faster wear out ✓ step or dimple formation in the center ✓ Electrode sticking ✓ weld splash 	<ul style="list-style-type: none"> ✓ No quality issues 	Zero quality issues with Mipalloy Tungsten Copper back cast nut welding electrode <ul style="list-style-type: none"> ✓ reduces down time ✓ reduces production cost ✓ reduces rejections ✓ improves product quality ✓ increases cost efficiency

Bottom Electrode

ITEM	ØD
M4	25
M5	25
M6	25
M8	25
M10	30
7/16"	30
M12	30

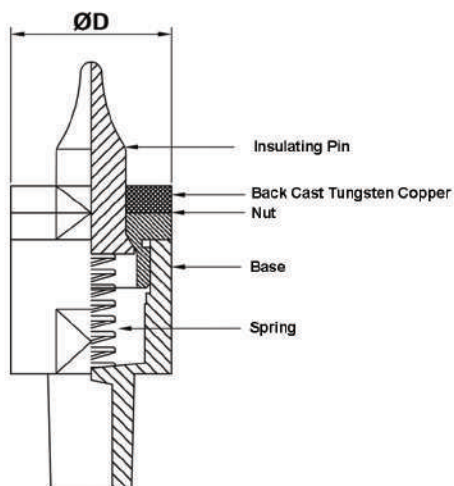

Top Electrode

ITEM	Ød
M4	5
M5	6
M6	8
M8	10
M10	12
7/16"	12
M12	14

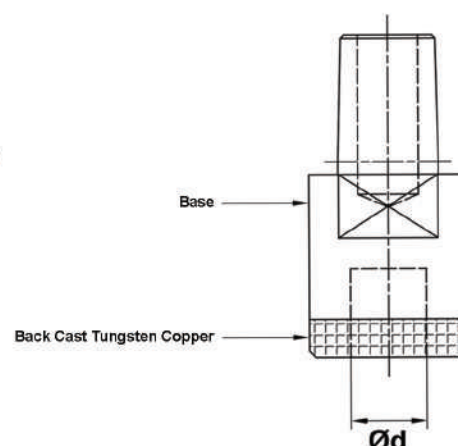

Projection Nut Welding Electrode with Pneumatic loaded pin

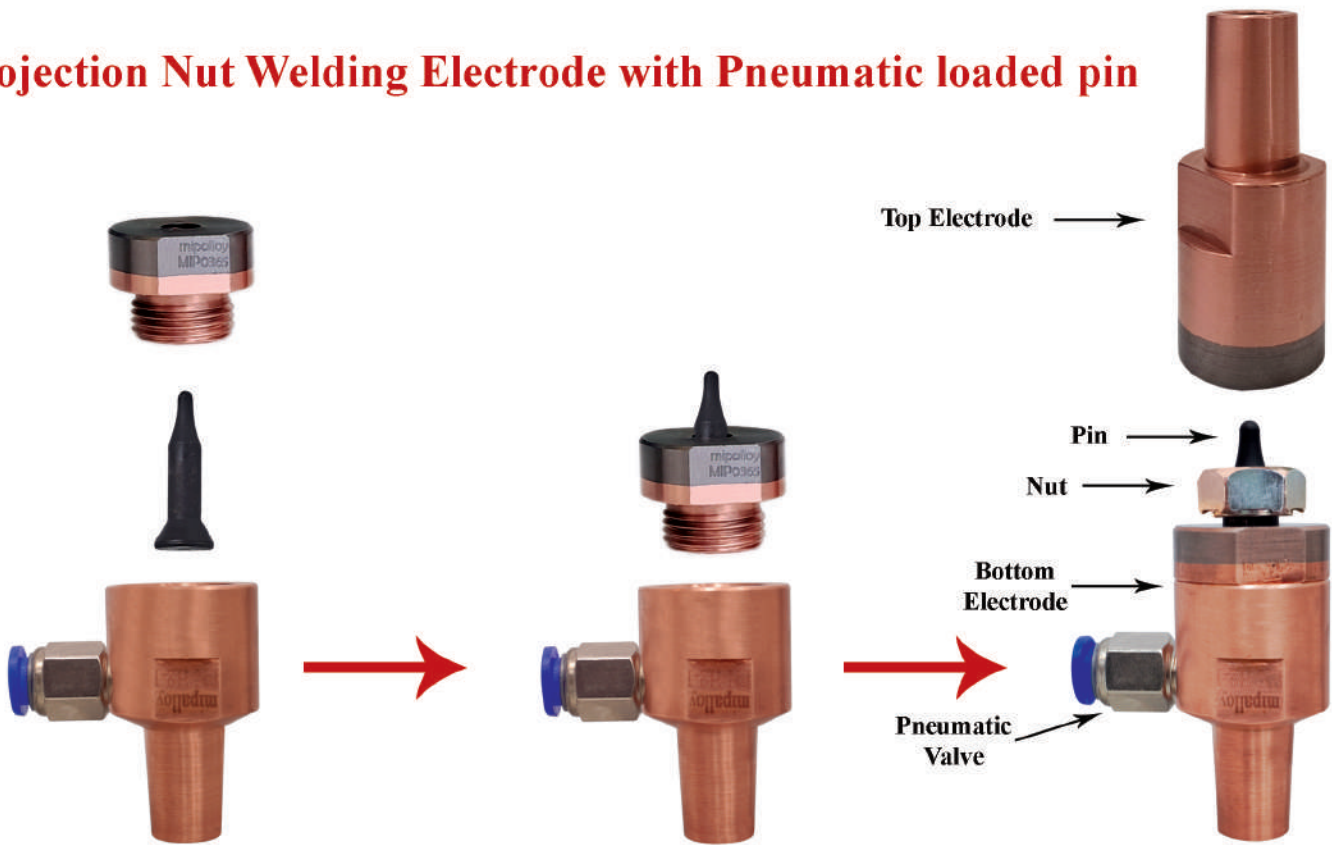

Projection Nut Welding Electrode with Spring loaded pin

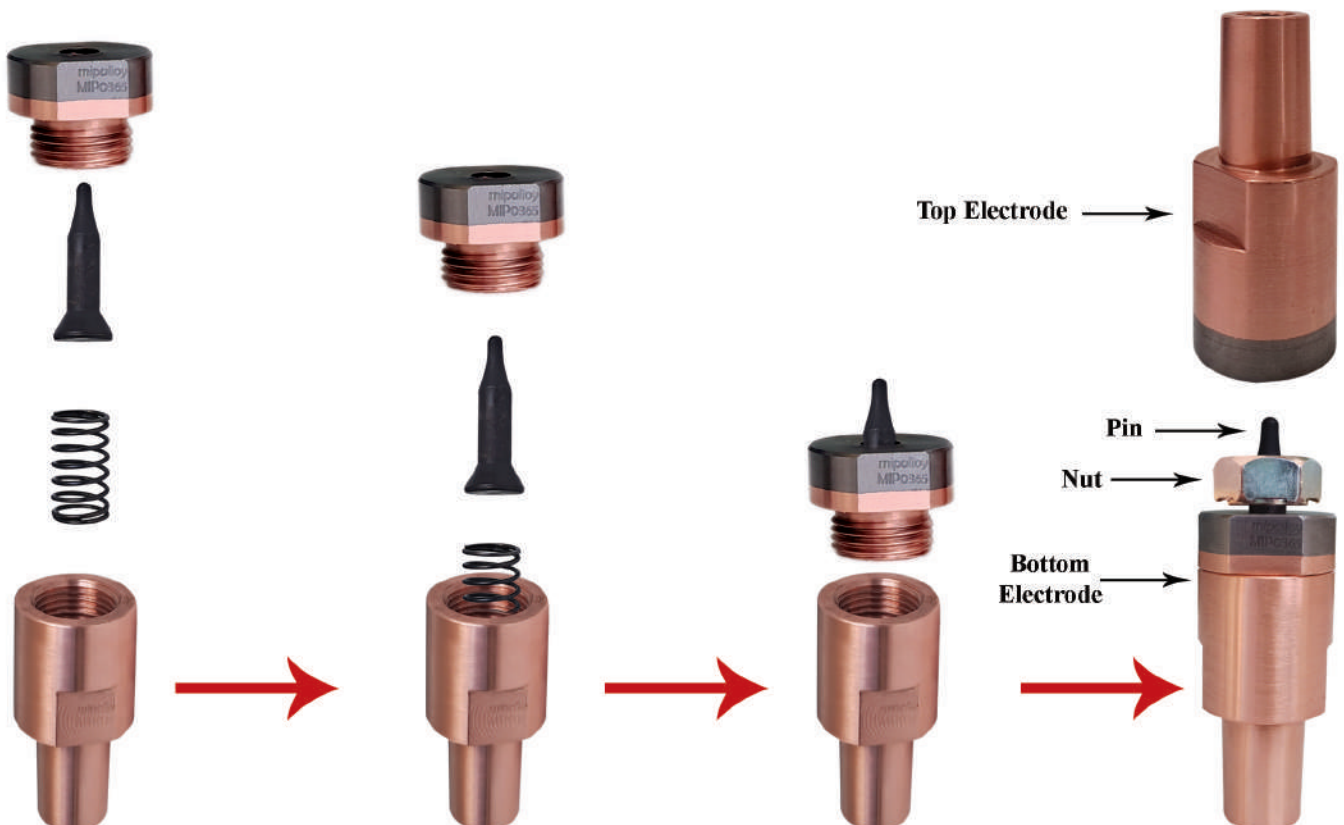

Nut welding process



Nut welding machine

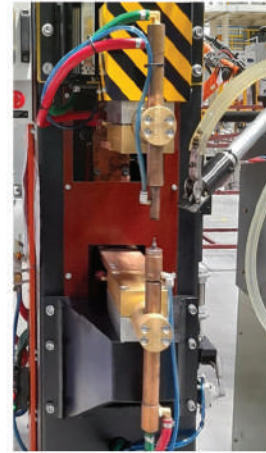

Nut welding pin manufactured by Mipalloy



Our partial list of customers:

